

FINCA SAN ISIDRO JOCOTENANGO,  
SACATEPEQUEZ, GUATEMALA.  
PBX: (502) 7831-1390 FAX: (502) 7831-1389  
E-MAIL: [exp@caoba.com](mailto:exp@caoba.com)  
[info@caoba.com](mailto:info@caoba.com)

**CAOBA DOORS U.S.A.**  
DOORS, WINDOWS & MORE  
PHILADELPHIA, PA 19143  
(800) 417-3667 FAX (215) 747-9908  
E-MAIL: [info@caobadoors.com](mailto:info@caobadoors.com)

Prepared for: GM CONSTRUCTION  
Project: MOBLEY RESIDENCE LOT 20

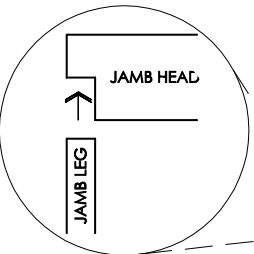

JAMB HEAD & LEGS FIT

JAMB HEAD

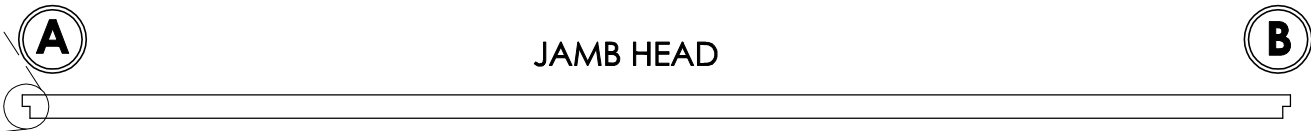

A

LEFT JAMB LEG

C

PIECE MORE LONG FOR ADJUST IN SITE

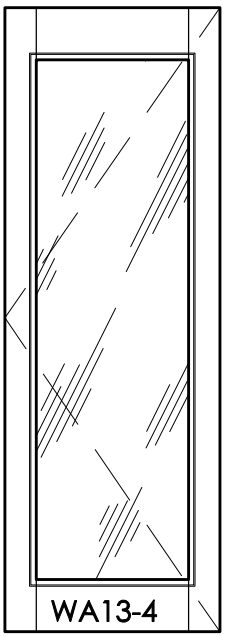
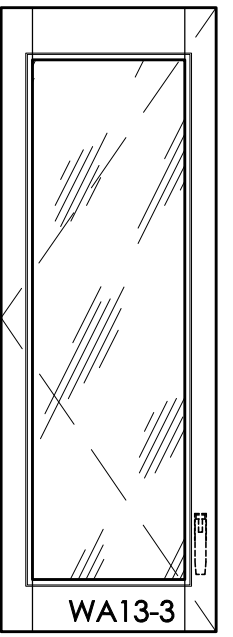
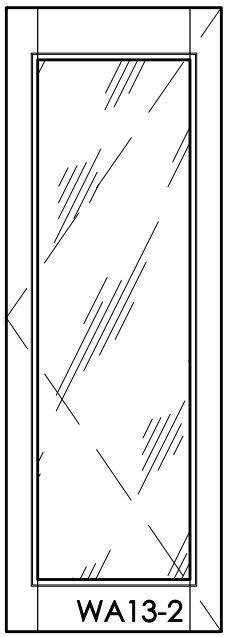
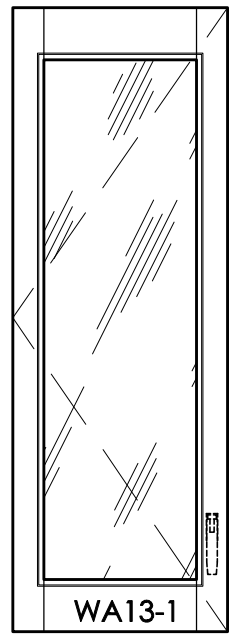

FLOOR CHANNEL

\*FLOOR CHANNEL IN FINAL LENGTH

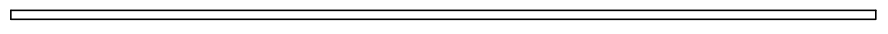

C

D

B

RIGHT JAMB LEG

D

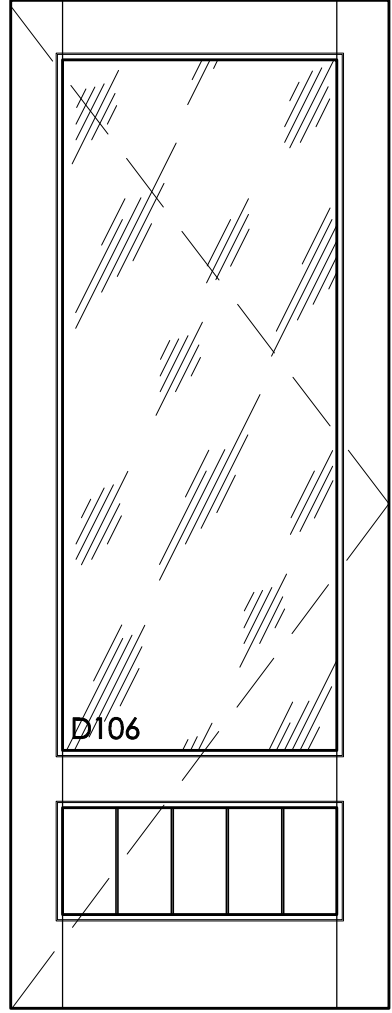

PIECE MORE LONG FOR ADJUST IN SITE

# ASSEMBLY INSTRUCTIONS

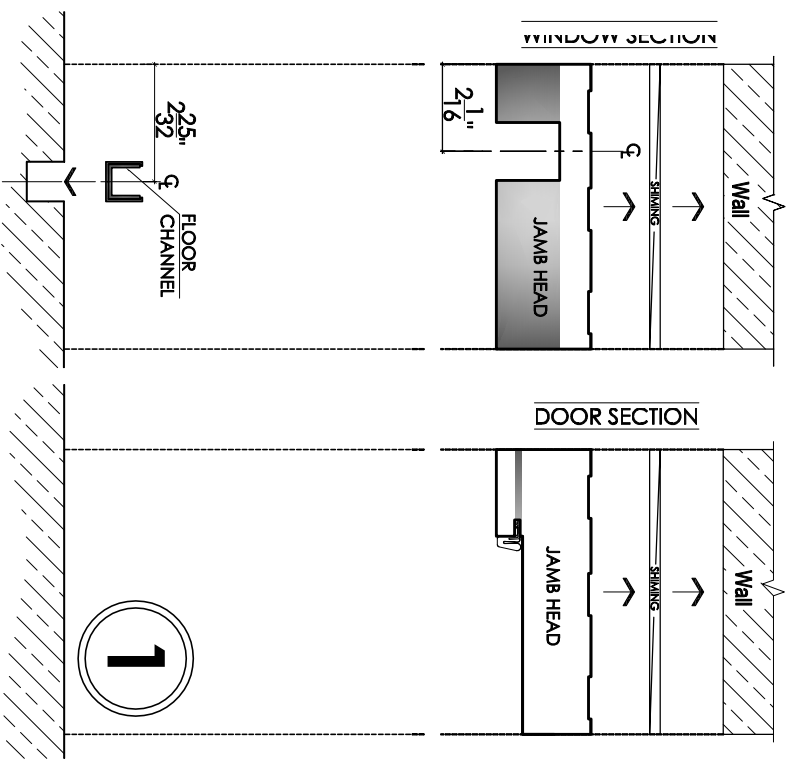

- STEP
- Install Jam opening & F

STEP 2:  
Install Jamb Legs in opening and Jamb Extension.

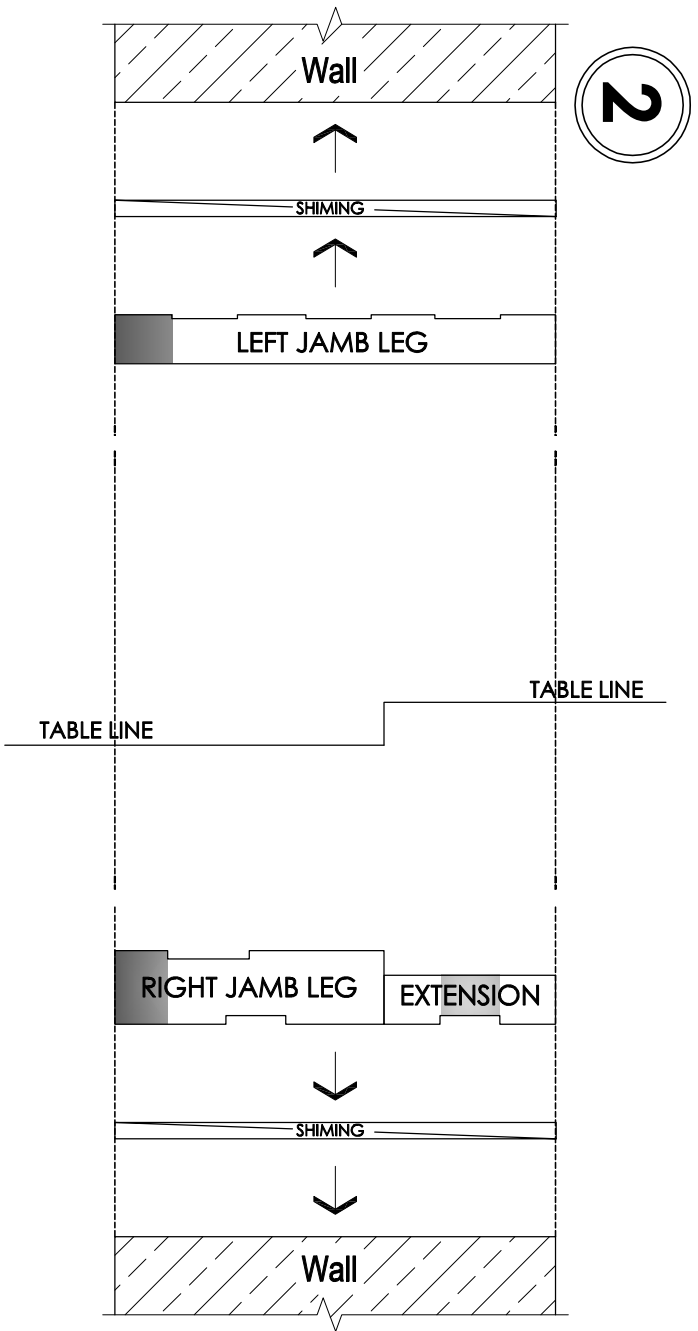

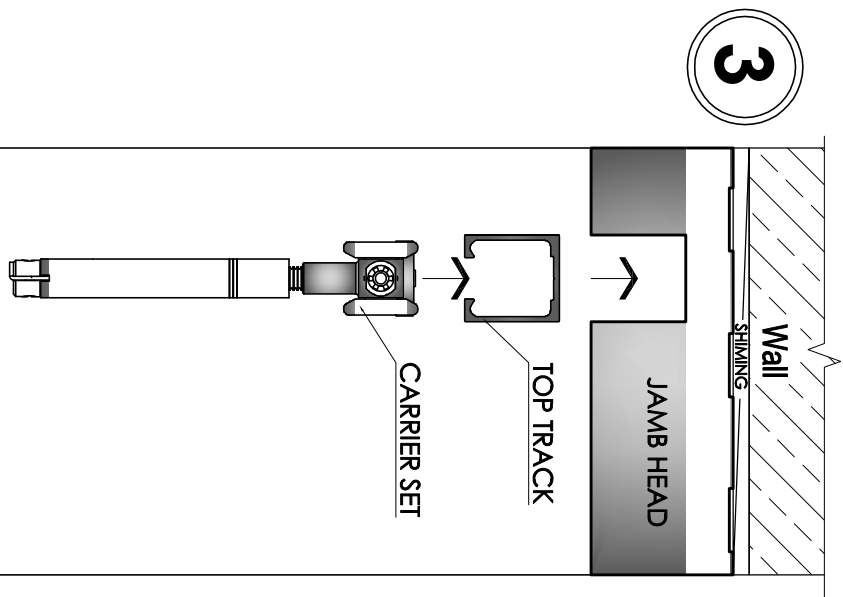

**STEP 3:**  
Insert carrier set in top track,  
then install Top Track in jamb  
head.

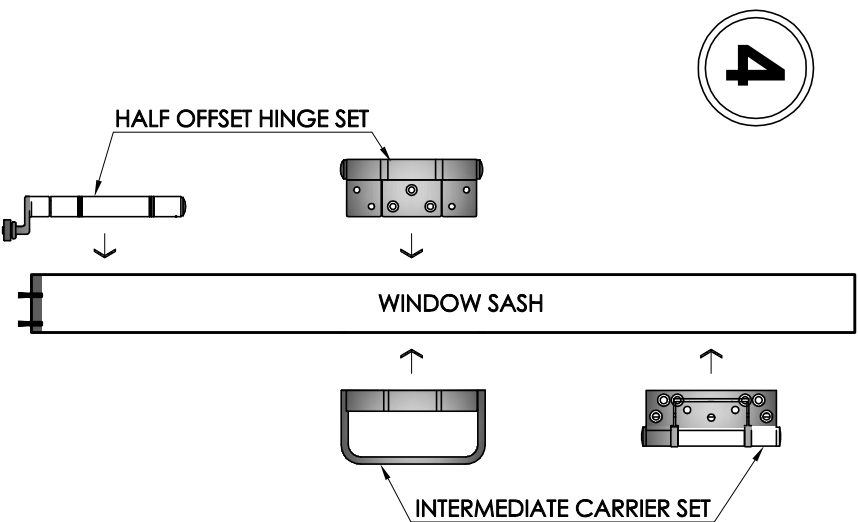

**STEP 4:**  
Install the rest of the Intermediate  
Carrier Set and install the Half  
Offset Hinge Set in windows sash.

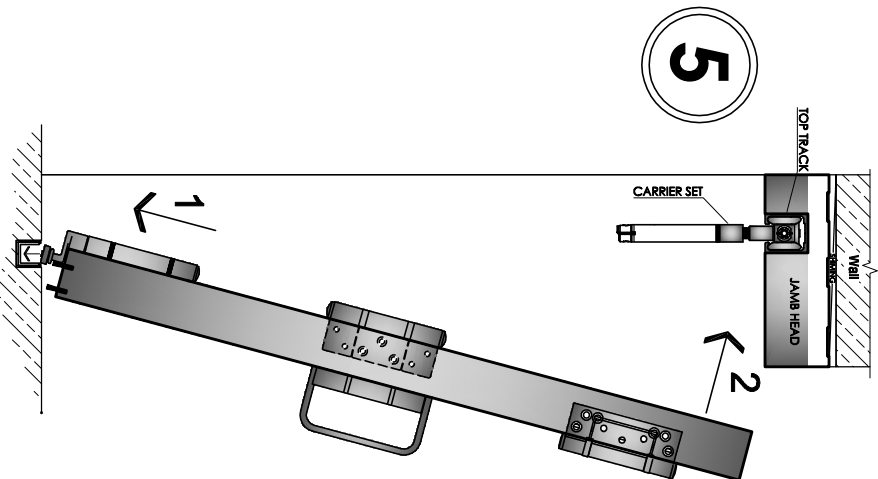

**5**

- STEP 5:
- Install windows sashes like d from the bottom of the sa push the top, adjust with C
  - Adjust sashes with Half Offs Set.

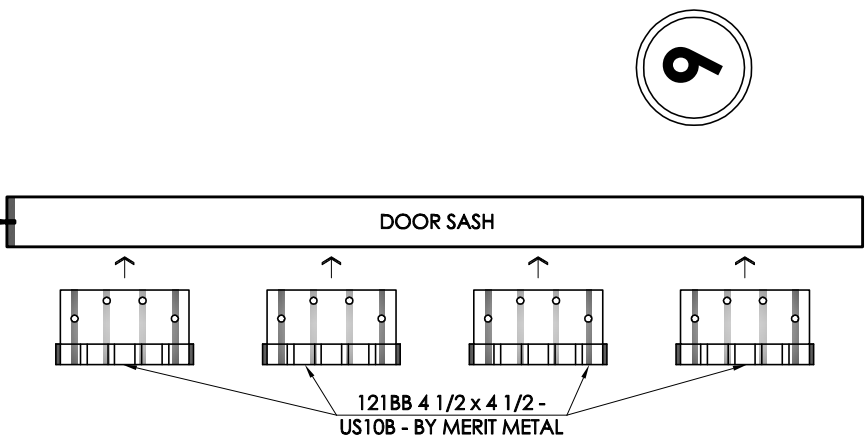

**6**

STEP 6:  
Install 4 1/2" x 4 1/2" Hinges by Merit Metal in door sash.

7

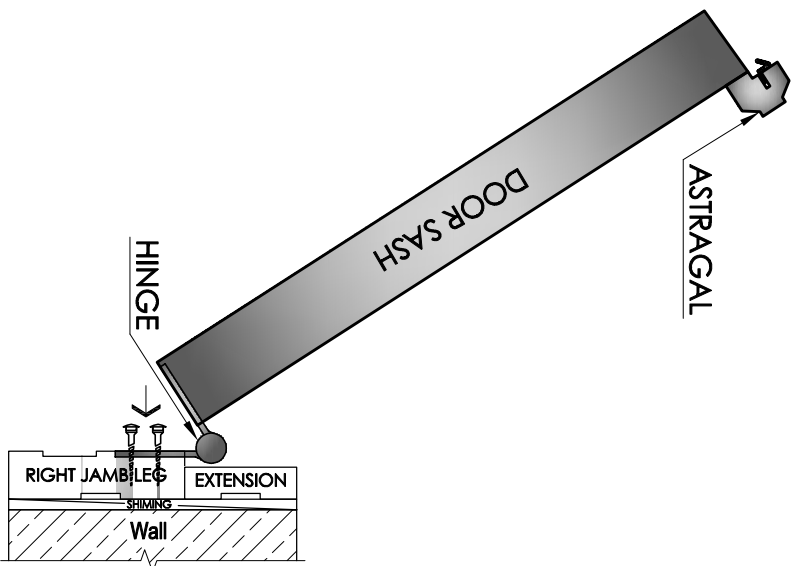

**STEP 7:**  
Install door sash in right jamb leg adjusting with the 4 1/2" x 4 1/2" Hinges.

**STEP 8:**  
Install Sash Stop in Jamb Legs and Jamb Head (Bi Folding window section)

**VERTICAL SECTION**

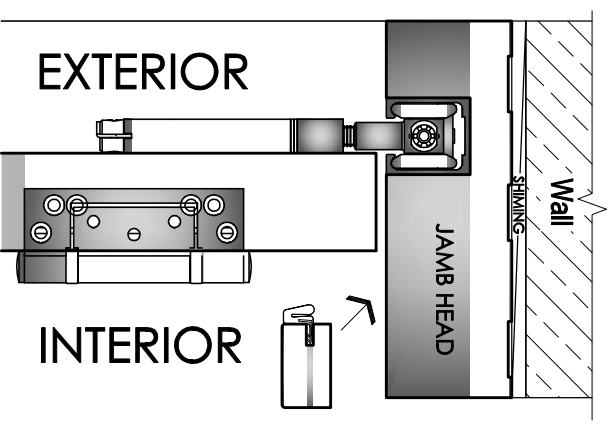

**HORIZONTAL SECTION**

